

# Solar Powered LED Street Lighting System

## Case Study-American University of Sharjah

Silpa Baburajan, Faisal Amin AlZarooni, Dr. Ahmed Osman

**Abstract**— This report describes an intelligent street lighting system with integrated solar energy resources and mobile application. Based on the rate of 0.45 fils/KW.hr, it cost AUS (American University of Sharjah) AED 373,852 per annum due to the usage of conventional high pressure sodium lamps in their street lighting. In our project, the proposed solution is to replace all of the conventional lamps with LED lamps in AUS and then control them using motion sensors and further develop a mobile application, using which we can control the switching ON/OFF of the LEDs and at the same time check for defected unit. Solar radiation energy is used to charge the battery during day time, and offer energy to the LEDs light equipment at night. A dimmable Modula is designed and integrated to the system to dim the LEDs at night from 01:00-06:00am. This system has a double advantage- it utilizes renewable energy and also reduces cost.

**Index Terms**—Energy, LightEmitting Diode(LED), power, solar

### I. INTRODUCTION

Until now, people around the globe depend on fossil fuels for their energy needs. Fossil fuels are limited in amount, expensive and polluting the environment. Therefore, a lot of research and developments have been proposed to solve those serious problems. One of the ways is to utilize renewable energy resources. Such resources are free of cost and also available in abundance. For our region solar energy is the most ample, direct and clean form of renewable energy especially in the UAE [1]. Total solar energy absorbed by the Earth is about 3,850,000 extra joules (EJ) in one year, which is even twice as much as all the non-renewable resources on the earth found and used by human being, including coal, oil, natural gas, and uranium [1]. Taking this idea into consideration, we are designing a solar powered LED street lights with mobile application for AUS campus. This technique utilizes energy-saving technology to reduce energy consumption, and hence improve utilization of solar energy available to us. Maintenance of public lighting system can be a hassle without proper monitoring system. In this project we are incorporating an all in one light monitoring system, which has motion sensor and dimming function.

### II. MOTIVATION

The American University of Sharjah is currently using high pressure sodium lamps for the street lighting purpose. The HPS lamps have several defects. It radiates large amount of heat and requires 250W for each lamps. The AUS campus has a total of 705 posts and every post has 3 or 4 lamps. The power required by a post is 750 to 1000 watts continuously working for 12 hours a day. This would consume a lot of energy at high prices.

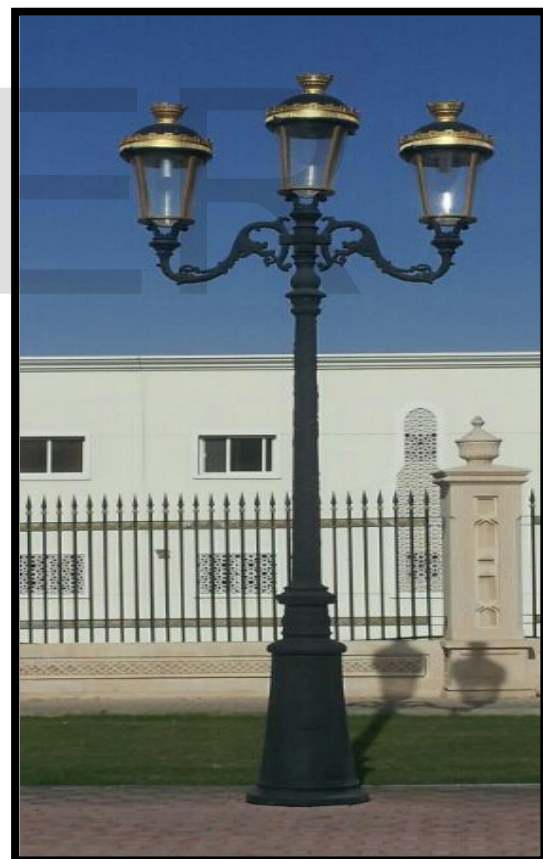

Figure 1: conventional Street Lamps in AUS

The current technology which is being used in AUS is:

- Lamps: OSRAM, Vialox, 250 Watts, High Pressure Sodium Lamps (HPS) [2].
- Ignitor: ZONDGERAT, Mzn 400 Sx.
- Ballast: BAG Electronics, HM/HIUAB, 250 Watts

for High Pressure lamps.

- Capacitor: DNA, CA /250, 35Mfd 240V.

In AUS, it costs AED 373,852 per annum due to the usage of conventional high pressure sodium lamps in their street lighting and the per unit rate was 0.45 fils/KW.hr. Shown below is a data of whole of the University City and then per unit rate was 45fils/KW.hr [2].

TABLE 1: POWER CONSUMPTION OF THE UNIVERSITY, SHARJAH

Title	Total-MWhr/day	Total-MWhr/year	Cost/day (AED)	Cost/year (AED)
AUS	5.1	1869	1024.25	373,851.5
Police Academy	1.1	405	222.00	81,030
Higher Colleges of Technology	1.8	665	364.5	133,042.5
Sharjah University	4.7	1743	955.5	348,757.5
City Hall	1.13	413	266.5	82,672.5
Library	1.17	427	234	85,410
Main Roads and Entrances	5.6	2057	1127.6	

In our project, we have proposed a solution, which is to replace all of the conventional lamps with solar powered LED lamps in AUS street lighting and then control them using motion sensors and further develop a mobile application, using which we can control the switching ON/OFF of the led and at the same time check for defected units. Smart Led Street Lighting System (SLSLS) with mobile application has been currently implemented in different areas of U.A.E such as on flyover just before Ajman City Centre and also in Abu Dhabi. Our project will be focusing on how can we implement SLSL in AUS and how much will be the upgrade cost from conventional street lamps to LEDs and the cost of each of them as well as how much is the saving for long time operation.

We are going to discuss later in the report why we choose a 40W LED bulb for our proposed design. Appendix A shows

the map of poles installed in AUS. The red, navy blue and greenish red dots show the location of the poles. This map was provided to us by the Sharjah Electricity and Water Authority (SEWA). Also given is the legend of the map which mentions the details of the legend and pole. As can be seen, the length of the pole used in AUS is 4.2m and 250W HPS lamps are used. Moreover, it shows the power consumption by the poles which have 3-4 lamps each.

### II. LED'S (PROPOSED SOLUTION):

It was found that AUS street lighting system has 705 lamp posts. Some has 3 lights and some has 4 lamps per post. Each light consumes 250 watts. The proposed design is to replace each lamp with 40 watts LEDs:

- LED's (proposed solution)
- Energy Consumption for 705 lamp posts each with 4 lamps:  
 $705 \times 40 \text{ W} \times 4 \text{ bulbs} = 112.8 \text{ kW}$
- Per night consumption  
 $112.8 \text{ kW} \times (12 \text{ hours/day}) = 1353.6 \text{ kW.hr}$
- Annual consumption in MW.hr  
 $1353.6 \text{ kW.hr} \times (365 \text{ days}) = 494.064 \text{ MW.hr}$
- Annual consumption in AED, with the rate 0.45 fils/KW.hr
- Cost = AED 2,22,328.8 / annum

### III. LEDS VS. CONVENTIONAL LAMPS

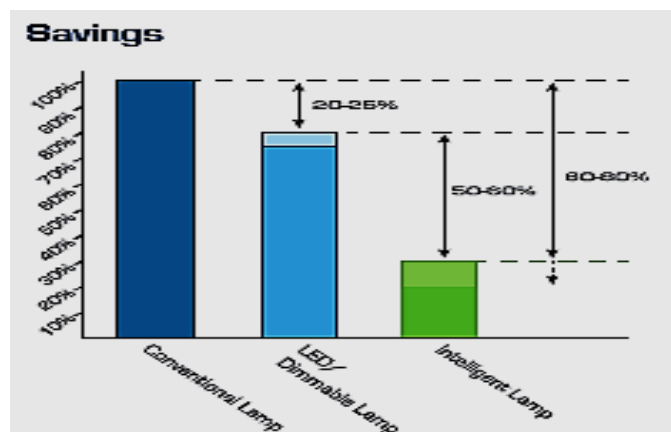

Figure 2: LED vs. Conventional Lamps [3]

Figure 2 shows the comparison in savings between the LED's and the conventional lamps. As we can see from the graph LED saves around 20-25% of energy less than the conventional lamps. But if we use intelligent lamps then we can save up to 80 % compared with the conventional lamps [3]. Intelligent lamps are those which can be controlled electrically to vary their properties or characteristics. In our system, we would be using a microcontroller with mobile

application to control the LEDs so as to vary their intensity.

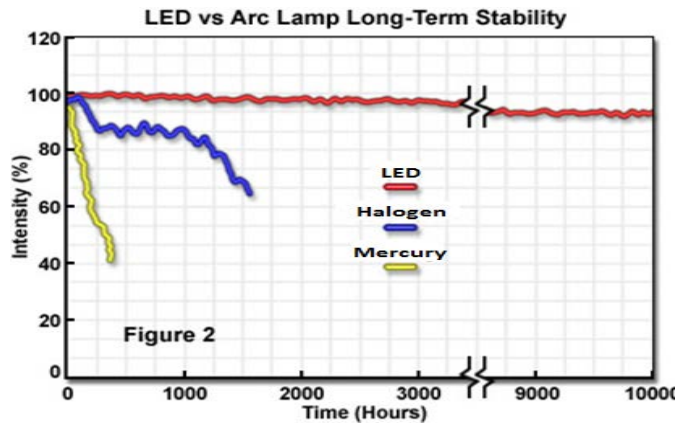

Figure 3: Characteristics of Intensity vs. Time [3]

Moreover, Figure 3 shows the intensity vs. Time of the different lamps. As the figure shows, LED has more life-time compared to halogen and mercury lamps. Appendix B shows the comparison of street lighting technologies between different types of lamps. As the table shows LED street lights can efficiently replace and outperform HID lamps with numerous advantages (long lifetime, directional light distribution, high light uniformity, no maintenance, durability, high color rendering index, etc.), all this without the emissions that would be harmful to the environment. Furthermore, the ignition time of LED is instant which a major requirement in our system as LED will be switched ON and OFF instantly to vary the intensity. On the other hand, one of the disadvantages of the LEDs is that it has a higher initial cost, but in the long run it will be cheaper because of its benefits. Therefore, we are choosing LED in our system because their advantages outperform its disadvantages.

#### IV. ADVANTAGES AND DISADVANTAGES OF SSL

For all the devices or systems that have ever been invented, there are always advantages and disadvantages that come along with them. A SSSL system is basically a system consisting of LED lamps and they can be dimmed or illuminated to any certain level depending on the user's profile. The following are some of the present advantages of use of SSL over conventional lighting [2]:

- 80% less energy use in addition to savings from high efficiency lamps.
- 50% or more savings per year in operating and maintenance costs.
- Better living environments with more reliable and safer lighting.
- The ability to mix lamp technologies to suit the needs of the city and accommodate new lamp types.
- An expandable infrastructure that supports multiple applications such as traffic, weather, and motion monitoring.
- Tremendous reduction in CO<sub>2</sub> emissions.
- Longer lifespan of LED lamps compared to HPS

lamps.

- Doesn't take any time for dimming and it is an instant process.

SSSL also has disadvantages which are as follows:

- Higher initial upgrade cost from conventional lamps to LEDs.

#### V. SCOPE

The main objective of implementing a SSL system is to conserve electricity which in turn conserves the raw materials required to generate electricity such as coal, oil and natural gas. The LED lights are dimmed at night from 1-6am and also we use the motion sensors so that with the detection of any motion, the LEDs are turned on for a specific amount of time. Hence, the LED doesn't require to operate with 100% brightness through out at night. This technique saves a lot of energy. This system has a double advantage- it utilizes renewable energy and also reduces consumption cost.

#### VI. SMART STREET LIGHT SYSTEM WITH ENERGY SAVING FUNCTION BASED ON THE SENSOR NETWORK

Currently, we waste enormous amounts of energy by using street lamps in a non-efficient way; that is, they turn on automatically when it is dark and light up automatically when it is day time. So the system they have proposed in this project is similar to ours because are using motion sensors, light sensor and a short distance communication network. Basically, the motion sensor detects either the pedestrian or a vehicle approaching and it lights up or dims and even switches off at times when no motion is detected. [7]

There are some attempts being made to reduce the energy wastes of street lamps, such as, a sensor light which will be controlled by a light sensor and optionally a motion sensor are used. But there is a delay in switching on the light using the motion sensor because the person or vehicle should be in close proximity to the street lamp instead it should switch on before the desired object comes close so that it lights up the street. Some companies and universities have developed central systems to control the street lights smartly using one central computer. These systems are suitable for controlling street lamps on large scale and are not at all suitable for small scale project.

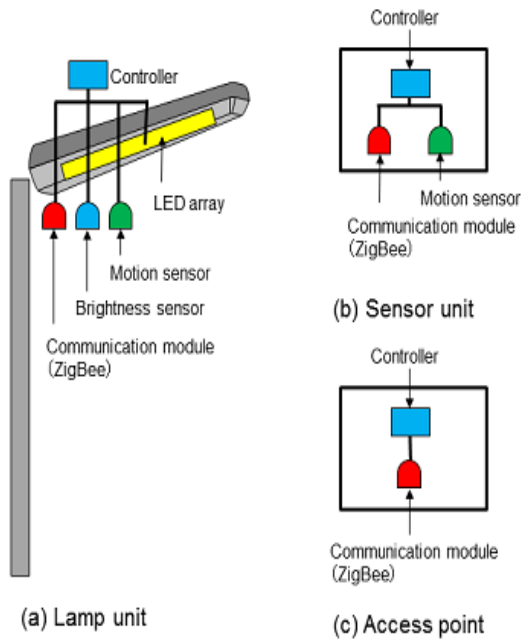

Figure 5: Components for the Smart Street Light [7]

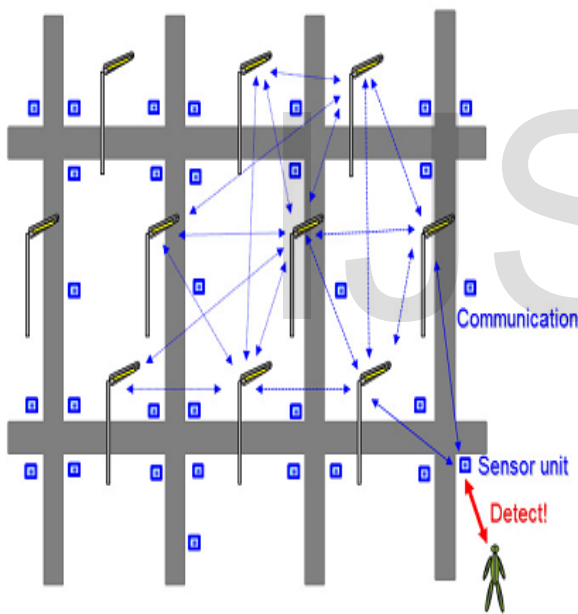

Figure 6: Object Detection Network [7]

VII. ASSUMPTIONS AND DEPENDENCIES:

In this project, our team is proposing a green and efficient solution for AUS campus street lighting. This solution saves energy by consuming less power and saves annual expenses of the country. After comparing different light sources, our team agreed upon using LEDs lamps because there are several advantages over the other types. The design of this project involves a solar system to save energy and power, LEDs to help in producing dimmable lightning and higher life span, and a motion sensor to control the switch ON/OFF of the

system at night I different periods.

VIII. DESIGN

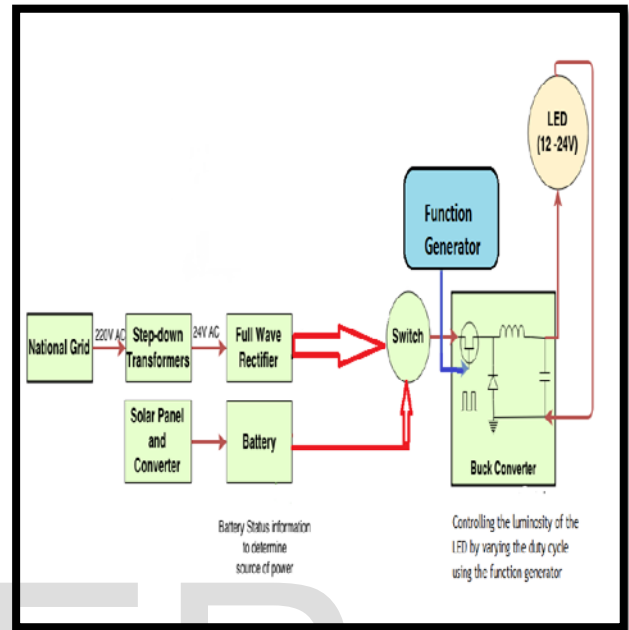

Figure 7: Overall System

VIII. SYSTEM DECOMPOSITION

The following are the main parts used for the SSL project:

1. Solar Panel

Solar panel is one of the most important parts of solar street lights, as solar panel will convert solar energy into electricity. There are 2 types of solar panel: mono-crystalline and poly-crystalline. Conversion rate of mono-crystalline solar panel is much higher than poly-crystalline.

2. Lighting Fixture

LED (Light Emitting Diode) is a solid state semiconductor device which can convert electrical energy into visible light. It is usually used as lighting source of modern solar street light. It is because of the fact that it has small size, low power consumption and long service life. The spectrum of the LED is mostly concentrated in the visible light spectrum, so it has a high luminous efficiency. Also the energy consumption of LED fixture is at least 50% lower than HPS (High Pressure Sodium) fixture which is widely used as lighting source in traditional street lights. Another advantage is that LED lacks warm up time that adds to its efficiency.



### 3. Rechargeable Battery

The electricity from solar panel is stored in the battery during the day and it provides energy to the fixture during night. The life cycle of the battery is very important to the lifetime of the light and the capacity of the battery will affect the backup days of the lights.

### 4. Controller

It is the controller which decides the switch on /off, charging and lighting and the dimming of the SLSL.

### 5. Pole

Strong Poles are necessary to all street lights, especially to solar street lights as there are components mounted on the top of the pole: Fixtures, Panels and sometime batteries. And wind resistance should also be taken into consideration when choosing the pole.

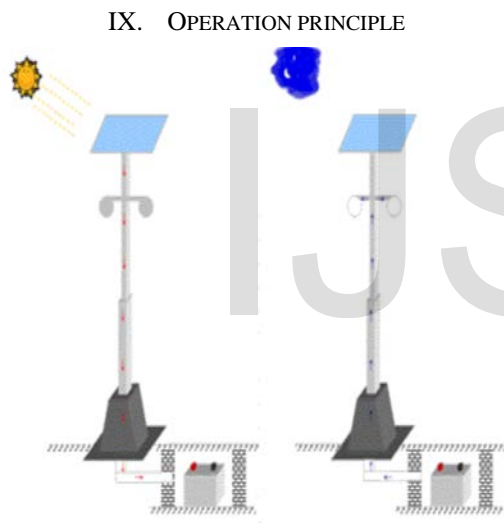

Figure 8: Operation Principle

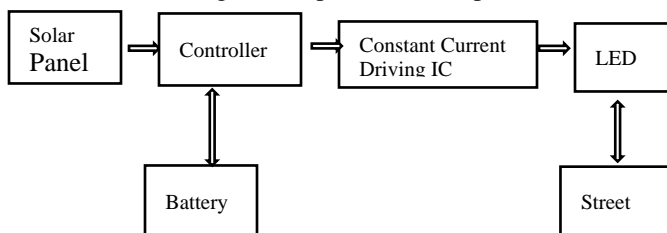

Figure 9: System Work Flow

According to principle of photovoltaic effect, the solar panels receive solar radiation during

the day time and then convert it into electrical energy through the charge and discharge controller, which is finally stored in the battery. When the light intensity reduced to about 10 lx during night and open circuit voltage of the solar panels reaches at a certain value, the controller has detected voltage value and then acts. The battery offers the energy to the LED light to drive the LED emits visible light at a certain direction. Battery discharges after certain time passes, the charge and discharge controller will act again to end the discharging of the battery in order to prepare next charging or discharging again

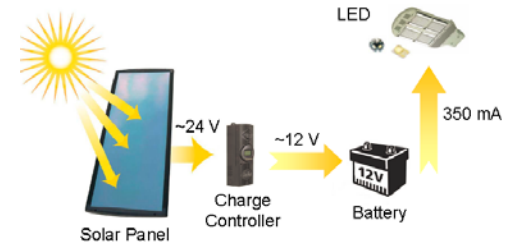

Figure 10: Solar Power- Block Diagram

### X. REQUIREMENT SPECIFICATIONS

American University of Sharjah (AUS) has a total of 705 no of poles. Each pole consists of 3-4 lamps, but on average we are taking 4 lamps in our system. Therefore the total number of lamps used in AUS is 2820 lamps.

Therefore to select an appropriate LED we had to know their technical specifications in order to quote them to a company. By thorough research we found companies which would suit our requirements to implement for the real time model. The UAE Solar Energy is one of the leading companies in LED industry which fulfills the standard requirement. The following shows the specifications of the street light.

#### Product Details:

- Model JNYT-40W -Solar panel
- Max power 18v/65W
- Life time 25 years
- Battery type : Lithium-FePo4battery
- Capacity 12.8V/30AH
- Life time 5 years
- LED Lamp
- Max power :12V/40W
- Led chip :Bridge lux from USA
- Lumen (LM) :4800-5200lm
- Led chip :40pcs
- Life time :50000hours

Product Parts:

- Solar Panel
- Li-Fe Battery
- LED
- MPPT controller
- Human intelligence induction System

Product Properties:

- Angle 120 degrees
- Charging by sun light :7 hours
- Full power more than 10hours
- Half power more than 20hours
- Work temp range (\*C) : 30-70
- Color temp range(k) :3000-6000
- Height range (m):4-5m
- Space range (m) :8-10m
- Material aluminum alloy
- Certificate CE / ROHS/ IP65
- Warranty 2 years

XI. IMPLEMENTED MODEL DETAILS

We wanted to implement the real system in our project, but due to the high cost of an actual system we decided to build a scaled down model on which we can implement our lighting control and mobile application. The cost of one entire set is AED 3500 and this was beyond the allowed range for us students. However, when the university is buying it in bulk, the cost reduces and also the university has to afford only its initial cost of setting up the solar powered LED. Because once it is set up, the LED then completely works on solar power, thus reducing the overall power consumption. The following are the details of our miniature model. Electrical students had to build the buck convertor on their own to interface the buck converter with the rest of the model.

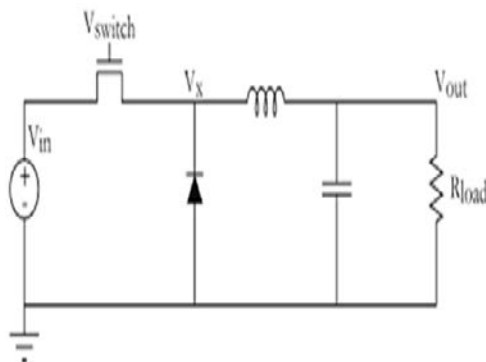

Figure11: Simple Buck Converter Circuit

The figure [10] above shows a basic buck converter circuit. The buck converter is used in our project to control the dimming function of the LED light using a power MOSFET. The MOSFET works as a switching regulator. In other words, the MOSFET voltage depends on the time of the duty cycle in

order to have the solar panels voltage (input voltage) to vary by turning the MOSFET ON/OFF in order to control the voltage transferred to the load. Our system is made up of a solar panel that supply energy of 12 volts and store it in a battery, the battery discharge this energy to the buck converter input voltage. The switching voltage of the MOSFET is a control signal that control the duty cycle. When the input voltage is high, the MOSFET turns ON allowing the input voltage to pass which is greater than the output voltage. Then the current through the inductor starts to increase and charges the capacitor. When the MOSFET turns OFF the current through the inductor starts pass through the diode producing a voltage equals to approximately zero. This voltage is less than the output voltage. Then the current through the inductor decreases and the capacitor starts to supply current to the load. This will produce a controllable buck converter in which it reduces the input voltage to any required output voltage for the load. [8]

The Buck Convertor Specifications:

- Output Power: P = 7 Watts
- Input Voltage :  $V_{input} = 12V$
- Current through one Led:  $I_{led} = P / V = 7/12 = 0.5833A$

Here we assume the load has 4 LEDs: Total current through the load:

- Current (I) through load  $= 4 * 0.5833 = 2.5 A$
- Duty Cycle:  $D = 0.5$
- $V_{out} = D * V_{in} = 6 V$
- Ripple Current:  $I_r = 30\% * I_{load} = 0.75A$
- $L = (V_{in} - V_{out}) * D / (I_{ripple} * Frequency)$

Assuming frequency to be 6Khz

- $L \geq 0.77mH$
- $V_{ripple} = 100mV$
- $Capacitance = ((1-D) * I_{load} * D * T) / V_{ripple} \geq 1.04mF$
- Diode should be able to handle current greater than 2.5A
- Mosfet  $\geq 3 * V_{in} \Rightarrow$  More than 30V
- $Capacitance = ((1-D) * I_{load} * D * T) / V_{ripple} \geq 1.04mF$
- Diode should be able to handle current greater than 2.5A
- Mosfet  $\geq 3 * V_{in} \Rightarrow$  More than 30V

XII. COST ANALYSIS

- Sodium lamps (Current system)
- Energy Consumption for 705 lamp posts each with 4 lamps:

$$705 \times 250W \times 4 \text{ bulbs} = 705 \text{ kW Per day consumption:}$$

$$705kW \times (12 \text{ hours/day}) = 8460 \text{ kW.hr}$$

- Annual consumption in MW.hr:  
 $8460 \times (365\text{days}) = 3087.8 \text{ MW.hr}$
- Annual consumption in AED, per fils rate 0.45  
fils/KW.hr
- Cost = AED 1,389,510 / annum

LED's (proposed solution):

- Energy Consumption for 705 lamp posts each with 4 lamps:
- $705 \times 40 \text{ W} \times 4\text{bulbs} = 112.8 \text{ kW}$
- Per day consumption
- $112.8\text{kW} \times (12\text{hours/day}) = 1353.6 \text{ kW.hr}$
- Annual consumption in MW.hr
- $1353.6\text{kW.hr} \times (365 \text{ days}) = 494.064 \text{ MW.hr}$
- Annual consumption in AED, per fils rate 0.45  
fils/KW.hr
- Cost = AED 222,328.8 / annum
- This cost estimation leads us to a ratio of 1: 6.24
- Cost of electrical components which includes lamp post, control box, solar panel, LEDs and battery = AED 3500[14]
- Initial Cost of setting up 705 Led lamp posts =  
 $\text{AED } 3500 \times 705 = \text{AED } 2,467,500$

Implemented Model Cost:

- Solar Panel with the controller and the battery =  
AED 500
- LED (7 W- Dc Dimmable) = AED 70
- Buck Converter Components = AED 40
- Total Cost = AED 610

### XIII. SIMULATIONS:

During the second phase of the project (ELE 491), we build the buck converter and interfaced with solar charged battery and function generator and tested the ON/OFF as well as dimming of the 7 Watts Led. The only problem we faced was the heating up of the mosfet. The problem was solved by using a heat sink with the mosfet.

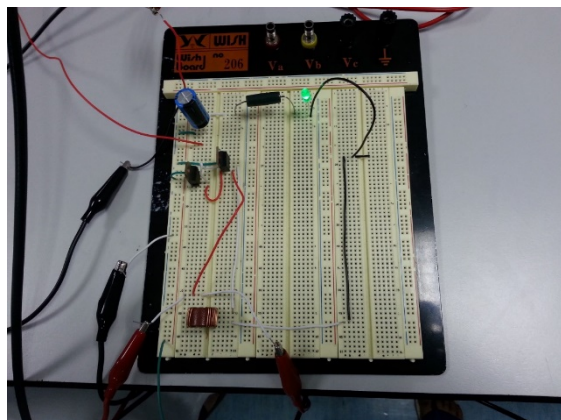

Figure 12: Buck Converter with Small LED

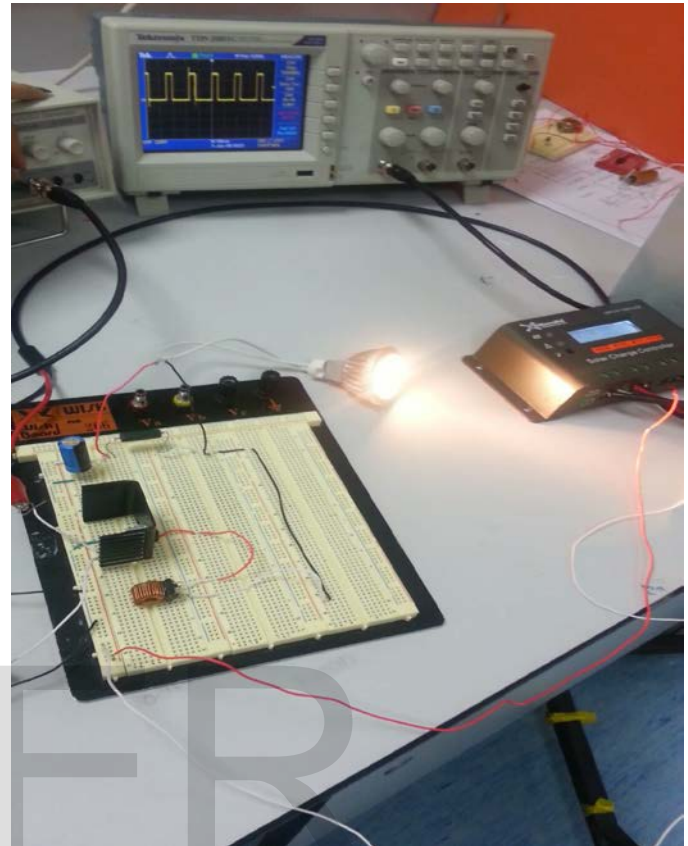

Figure 13: Dimming the 7Watt LED by Varying the Duty Cycle

### XIV. CONCLUSIONS AND FUTURE WORK:

At our university, the first engineering course was NGN110. We learned that engineers face problems in societies that need to be solved. We are problem solvers. United Arab Emirates (UAE) suffer from high power consumption and this is a problem. As engineers, we decided to overcome this problem by introducing the smart LED street lighting system with mobile application. This technology is the main purpose that will help the UAE to save energy, power and annual cost. Recently, our main objective is to reduce the consumption of power in the streetlight at the American University of Sharjah (AUS). After long research of comparing different streetlights, our team decided to use LEDs in our system because their advantages outperform the other types as well as its disadvantages. The process starts by replacing the halogen lamps used now at AUS by LEDs. These LEDs will consume energy stored in a battery from the solar panels rather than the national grid. However, the national grid will be used for emergencies only; emergencies such as the failure of the solar panels to save energy due to dusts in the air or absence of sun light.

The software in the controller is configured to run automatically and requires no additional setup, i.e., the device works in plug-n-play mode. Moreover, the server was

designed such that new applications can be developed easily using services offered by the server.

Our system scenario is to charge the rechargeable battery during the presence of sunlight. Then, during sunset the battery will start discharging leading the LEDs to lighten. In addition, there will be sensors in our system to help identifying incoming cars because the LEDs are dimmable, so from one to six (A.M.) the lights will be dimmed. With the use of sensors it will sense a car which will enlighten the LEDs.

#### XV. REFERENCES

- [1] Alternative Energy. "Solar Energy," [www.altenergy.org](http://www.altenergy.org). [Online]. Available: <http://www.altenergy.org/renewables/solar.html> [Accessed: Dec. 18, 2014].
- [2] Mazam .J. (2007), "Street Lighting Energy Saving Systems for University City", AUS, p.10.
- [3]"HPS: How it Works". Retrieved November, 2014 Available: <http://www.edisontechcenter.org/SodiumLamps.html>
- [4] GRAH LED LIGHTING. "Street lighting technology comparison," [www.grahlighting.eu](http://www.grahlighting.eu). [Online]. Available: <http://www.grahlighting.eu/learning-centre/street-lighting-technology-comparison> [Accessed: Jan. 03, 2015].
- [5] Design Recycle Inc. "Comparison Chart LED Lights vs. Incandescent Light Bulbs vs.CFLs," [Online]. Available: <http://www.designrecperycleinc.com/led%20comp%20chart.html> [Accessed: Jan. 03,

2015].

[6] Y. Fujii, N. Yoshiura, A. Takita, and N. Ohta, "Smart street light system with energy saving function based on the sensor network," Berkeley, CA, United states, 2013, pp. 271-272.

[7] Our Latest Projects of Solar Street Lighting, Solar Street Lights. Internet: <http://www.solarstreetlights.net/latestprojects.htm>, 2008 [Jan. 03, 2015].

[8] M. Thomson, "Circuits & Electronics, Voltage Converter," 5 November 2011. [Online]. Available: <http://mike-thomson.com/blog/?p=246>. [Accessed 14 May 2015].